

NT1-296 Rack NT1U-223TC Card Installation Instructions

The NT1-296 Rack is designed to be used in conjunction with Tone Commander NT1U-223TC ISDN Network Termination cards. A maximum of 16 cards can be used in each rack.

Each NT1U-223TC card contains three NT1 circuits, with support for two terminals per circuit. A fully loaded rack has a maximum capacity of 48 NT1s and can support 96 ISDN terminals.

The rack supplies power to the NT1 units, and terminal equipment connected to the NT1s, from a local 120 VAC outlet.

Optional NT1-200/296 Battery Backup Power Supply and NT1-200 Add-on Battery can be added to the rack to enable uninterrupted NT1 and ISDN terminal power during a power failure. A fully loaded rack will operate for 1 hour with the Battery Backup.

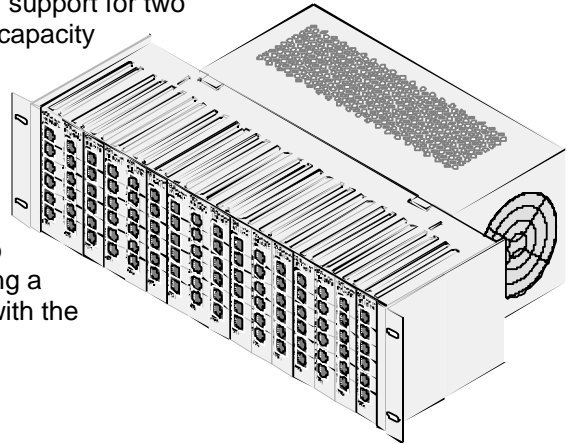

Specifications

NT1-296 Rack (with Power Supply)

Physical Dimensions	5.2" H x 17.25" W x 6.1" D (12.3" D with Power Supply, rack mount)
U Interface	(2) 50 position ribbon cable connectors (Amphenol type)
S/T Interface	(8) 50 position ribbon cable connectors (Amphenol type)
Weight	3 lbs. (7.5 lbs. with Power Supply)
Operating Temperature	0° - 50° C (32° - 122° F)
Humidity	5% to 95%, non-condensing
Short Circuit Protection	individual self-resetting current limiting for each NT1 circuit; 20 W max. per NT1
Available Power for Terminals	5 W average per NT1 circuit

NT1U-223TC Card

NT1 Circuits	3 per card
Operating Voltage	34-56.5 VDC
Power Consumption	1.8 W typical
Physical Dimensions	5.2" H x 1" W x 5.5" D
S/T Interface	(2) 8 position modular jacks per NT1 circuit (front panel access); 50 pin ribbon cable access through rack
U Interface	50 pin ribbon cable access through rack
Weight	7 oz.
Operating Temperature	0° - 50° C (32° - 122° F)
Humidity	5% to 95%, non-condensing

NT1-296 Rack Power Supply

Power Requirements	120 VAC, 60 Hz, single phase, 4 A max.
Output	42-55 VDC nominal 300 W max.
Physical Dimensions	4" H x 12.4" W x 6.2" D
Weight	4.5 lbs.

Contents of Shipping Boxes

Rack:

- | | |
|-----------------------|--|
| (1) NT1-296 Rack | (4) 10-24 x ¼" mounting bracket screws |
| (1) Power Supply | (2) #6 self-tapping screws for securing Power Supply |
| (2) Mounting brackets | (1) Installation Instructions (this document) |

Card:

- | |
|---------------------|
| (1) NT1U-223TC Card |
| (1) Faceplate |

Tone Commander NT1-296 Rack / NT1U-223TC Installation Instructions



Important Safety Instructions

- This equipment is intended for installation in a restricted access location (dedicated equipment rooms, equipment closets, or the like) in accordance with Articles 110-16, 110-17, and 110-18 of the National Electrical Code, ANSI/NFPA No. 70.
- Never install telephone wiring during a lightning storm.
- Never install telephone jacks in wet locations unless the jack is specifically designed for wet locations
- Never touch uninsulated telephone wires or terminals unless the telephone line has been disconnected at the network interface.
- Use caution when installing or modifying telephone wires.
- Do not mount the NT1-296 Rack within 12" of a heat source.
- The socket-outlet shall be installed near the equipment and shall be easily accessible.

Rack Mounting

1. The NT1-296 Rack can be mounted in an EIA standard 19" commercial or 23" telco rack.
2. Attach the mounting brackets to the rack in a 19" or 23" mounting position as needed, using the supplied mounting bracket screws.
3. Mount the NT1-296 to the 19" or 23" rack standards using suitable fasteners.

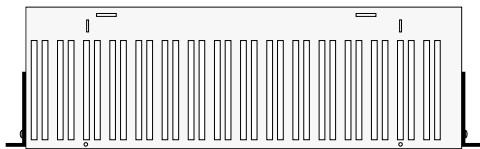

Bracket Positions – 19" Rack

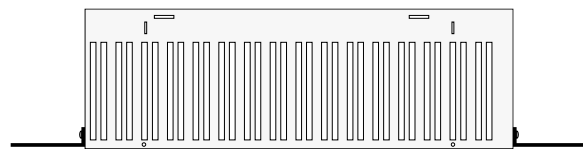

Bracket Positions – 23" Rack

Power Supply

Attach ribbon cable connectors to the back panel before mounting the power supply (refer to page 5).

1. Plug the power output cable (red and black wires) into the POWER connector on the rack back panel.
2. Insert the tabs on the top edge of the power supply into the slots on the top panel of the NT1-296 as shown below.
3. Pivot the power supply down until the lower tabs lock into the slots on the rack back panel. You may need to lift the power supply slightly to insert the lower tabs into the rack. **Make sure the power cable is not pinched.**
 - To remove the power supply, lift up, then pull back on the power supply to disengage the lower tabs.

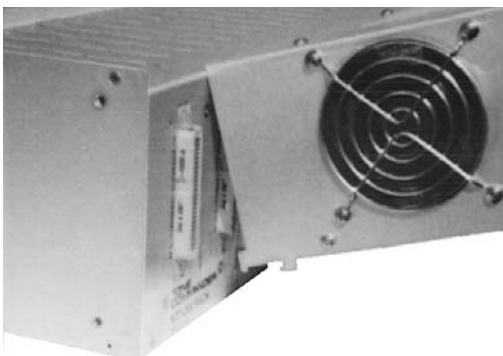

Rack Mount Power Supply Installation

Wall Mounting

Note – When mounting the NT1-296 Rack in conjunction with a Battery Backup unit, refer to the NT1-200 Battery Backup/NT1-200 Add-on Battery Installation Instructions (doc. #13-102688) for proper mounting positions.

1. Remove all circuit cards from the rack. Disconnect the power supply and set it aside.
2. Attach the mounting brackets to the rack in the wall mounting position, using the supplied mounting bracket screws.
3. Fasten a plywood sheet to the wall.
4. Hold the rack up to the wall to mark the hole locations, then pre-drill the mounting holes for the rack. Make sure that the power cord can reach a local 120 VAC, 60 Hz, single phase grounded power outlet.
5. Attach the rack to the plywood using four suitable fasteners (such as #10x $\frac{3}{4}$ " pan head self-tapping screws). **A fully loaded NT1-296 Rack weighs 14.5 lbs.**

When mounting the rack to the wall, ensure that the power supply vents are not obstructed or flush against the wall.

6. Remove the top bracket mounting screw on each side of the rack and tilt the rack forward to connect ribbon cable connectors. After all cables are connected, replace mounting screws and install the cards – see page 4.

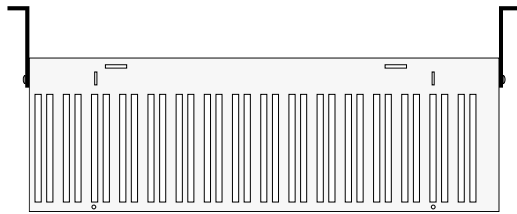

Bracket Positions – Wall Mount

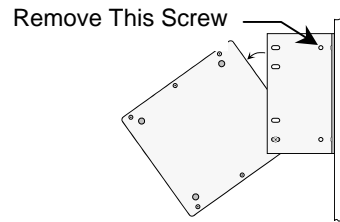

Tilting Rack for Cable Access

Power Supply

For wall mounting configurations, the power supply mounts on top of the NT1-296.

1. Slide the grooved tabs on the power supply into the slots in the front of the rack top panel as shown below. Use the slots directly behind the two screw holes at the front of the top panel.
2. Tilt the rear of the power supply down to insert the back tabs into the rack top panel, then push the power supply back to secure it.
3. Insert the two retaining screws into the rack top panel, in front of the power supply, to prevent the power supply from sliding forward.
4. Plug the power supply output cable (red and black wires) into the POWER connector on the rack back panel.

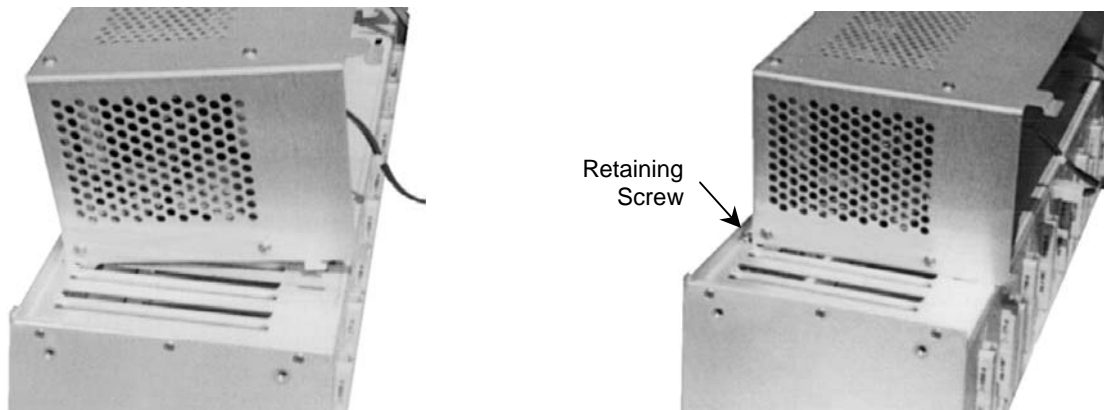

Wall Mount Power Supply Installation

Tone Commander NT1-296 Rack / NT1U-223TC Installation Instructions

NT1U-223TC Card Installation

The termination switch for each NT1 circuit must be set prior to inserting the card. Available settings are OFF, 100Ω, and 50Ω. There are three switches per card.

Set the termination switch to match the premises wiring between the NT1 and the terminals. Several typical wiring configurations are shown below, with the appropriate termination switch setting.

Fixed or adaptive timing selection is not required.

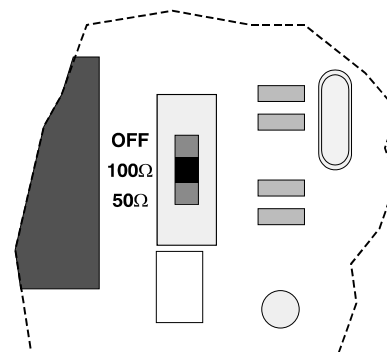

Basic Multipoint

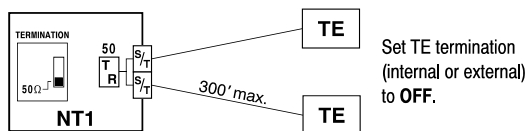

Basic Multipoint using Distribution Block

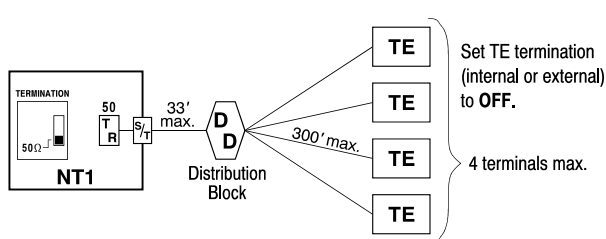

Short Multipoint

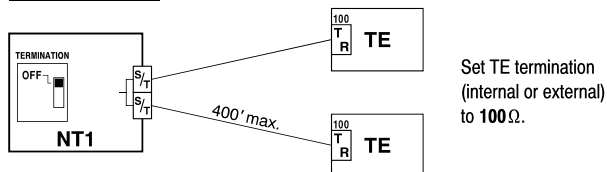

Extended Point-to-Point

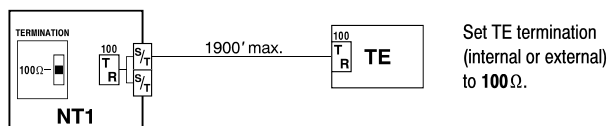

After setting the termination switches, insert each card into the rack. The components on the card face the right side of the rack. Make sure that the connector on the back of the card is fully seated. Cards may be inserted or removed from an operational rack without affecting the performance of the other NT1 cards.

Using a fine-point marking pen, write the directory number or other identifier for each terminal on the card faceplate. Carefully place the faceplate over the front of the card, with the connectors and LED indicators located inside of the cutout on the faceplate. The faceplate is secured by magnetic strips on the rack.

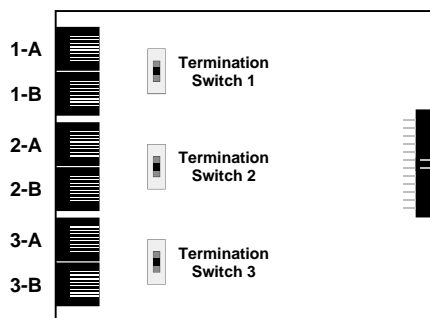

NT1U-223TC Card

Cable Connections

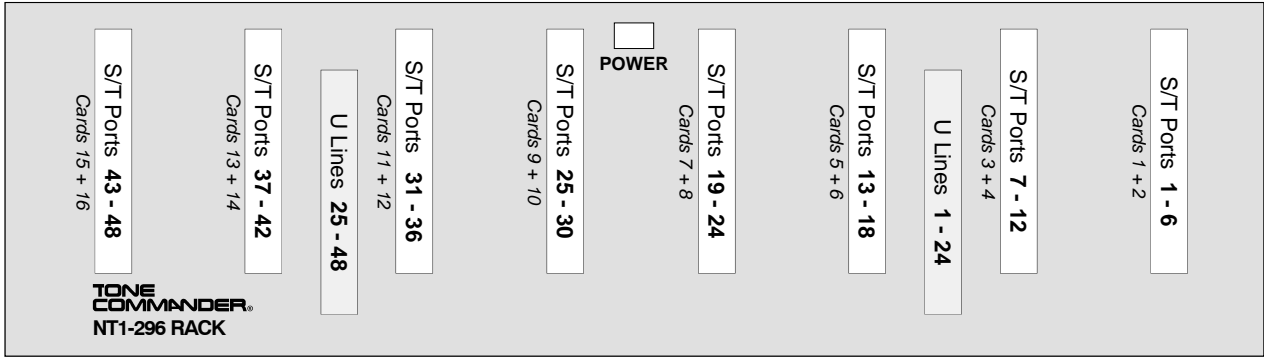

Back Panel Connectors

All rack S/T and U connectors are female; male connectors are required on the cable ends.

U Interface

Plug each U interface cable from the network interface block into the appropriate 50-pin U interface connector on the rack rear panel. See Table 2 for connector pinout. The rack uses self-locking connectors; to remove a cable, use a small tool to press in the tabs on the ends of the connector.

S/T Interface

The S/T interface for each terminal can be connected one of two ways:

1. Modular jacks on the front of the NT1U-223TC cards – for terminal equipment or patch panel connection via an 8-position modular phone cord. Connecting cords must be Category 3 or higher with T568 A or T568 B wiring. See Table 1 and the figure below for jack pinout.
Two parallel-wired jacks are provided per NT1 circuit (3 sets per card), for two terminals connected in a multipoint arrangement.
2. 50-pin ribbon connectors on the rack back panel – for terminal equipment connection via a punch-down block. See Table 2 for connector pinouts.

Connect the terminal wall jacks to 4-pair cables as shown in Table 1. Punch down the cables to the crossconnect blocks in the order shown in Table 1. Note that pairs 1-2 and 3-6 for T568 A jacks are reversed from T568 B jacks.

Pin #	Signal	Wire Color	
		T568 A	T568 B * (AT&T)
5	Tx-	WHT-BLU	WHT-BLU
4	Tx+	BLU	BLU
1	N/C	WHT-GRN	WHT-ORN
2	N/C	GRN	ORN
3	Rx+	WHT-ORN	WHT-GRN
6	Rx-	ORN	GRN
7	-48V	WHT-BRN	WHT-BRN
8	GRD	BRN	BRN

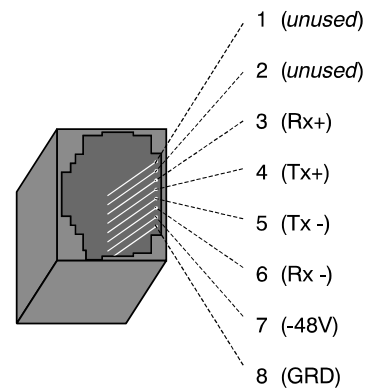

Table 1 – Modular Jack Pinout

* **T568 B (AT&T 258A) jacks are recommended;** they allow conventional station pair ordering when connecting to S/T punchdown blocks.

Tone Commander NT1-296 Rack / NT1U-223TC Installation Instructions

Pin No.	Wire Color	U Lines 1-24	Card Number	U Lines 25-48	Card Number
26	WHT-BLU	U1 -	1	U25 -	9
1	BLU-WHT	U1+		U25+	
27	WHT-ORN	U2 -		U26 -	
2	ORN-WHT	U2+		U26+	
28	WHT-GRN	U3 -		U27 -	
3	GRN-WHT	U3+		U27+	
29	WHT-BRN	U4 -	2	U28 -	10
4	BRN-WHT	U4+		U28+	
30	WHT-SLT	U5 -		U29 -	
5	SLT-WHT	U5+		U29+	
31	RED-BLU	U6 -		U30 -	
6	BLU-RED	U6+		U30+	
32	RED-ORN	U7 -	3	U31 -	11
7	ORN-RED	U7+		U31+	
33	RED-GRN	U8 -		U32 -	
8	GRN-RED	U8+		U32+	
34	RED-BRN	U9 -		U33 -	
9	BRN-RED	U9+		U33+	
35	RED-SLT	U10 -	4	U34 -	12
10	SLT-RED	U10+		U34+	
36	BLK-BLU	U11 -		U35 -	
11	BLU-BLK	U11+		U35+	
37	BLK-ORN	U12 -		U36 -	
12	ORN-BLK	U12+		U36+	
38	BLK-GRN	U13 -	5	U37 -	13
13	GRN-BLK	U13+		U37+	
39	BLK-BRN	U14 -		U38 -	
14	BRN-BLK	U14+		U38+	
40	BLK-SLT	U15 -		U39 -	
15	SLT-BLK	U15+		U39+	
41	YEL-BLU	U16 -	6	U40 -	14
16	BLU-YEL	U16+		U40+	
42	YEL-ORN	U17 -		U41 -	
17	ORN-YEL	U17+		U41+	
43	YEL-GRN	U18 -		U42 -	
18	GRN-YEL	U18+		U42+	
44	YEL-BRN	U19 -	7	U43 -	15
19	BRN-YEL	U19+		U43+	
45	YEL-SLT	U20 -		U44 -	
20	SLT-YEL	U20+		U44+	
46	VIO-BLU	U21 -		U45 -	
21	BLU-VIO	U21+		U45+	
47	VIO-ORN	U22 -	8	U46 -	16
22	ORN-VIO	U22+		U46+	
48	VIO-GRN	U23 -		U47 -	
23	GRN-VIO	U23+		U47+	
49	VIO-BRN	U24 -		U48 -	
24	BRN-VIO	U24+		U48+	
50	VIO-SLT	-	-	-	-
25	SLT-VIO	-	-	-	-

Table 2 – U Interface 50-pin Connector Pinouts

Pin No.	Wire Color	S/T Ports 1-6	S/T Ports 7-12	S/T Ports 13-18	S/T Ports 19-24	S/T Ports 25-30	S/T Ports 31-36	S/T Ports 37-42	S/T Ports 43-48
26	WHT-BLU	Tx1 -	Tx7 -	Tx13-	Tx19 -	Tx25 -	Tx31 -	Tx37 -	Tx43 -
1	BLU-WHT	Tx1+	Tx7+	Tx13+	Tx19+	Tx25+	Tx31+	Tx37+	Tx43+
27	WHT-ORN	-	-	-	-	-	-	-	-
2	ORN-WHT	-	-	-	-	-	-	-	-
28	WHT-GRN	Rx1 -	Rx7 -	Rx13 -	Rx19 -	Rx25 -	Rx31 -	Rx37 -	Rx43 -
3	GRN-WHT	Rx1+	Rx7+	Rx13+	Rx19+	Rx25+	Rx31+	Rx37+	Rx43+
29	WHT-BRN	-48V1	-48V7	-48V13	-48V19	-48V25	-48V31	-48V37	-48V43
4	BRN-WHT	GRD1	GRD7	GRD13	GRD19	GRD25	GRD31	GRD37	GRD43
30	WHT-SLT	Tx2 -	Tx8 -	Tx14 -	Tx20 -	Tx26 -	Tx32 -	Tx38 -	Tx44 -
5	SLT-WHT	Tx2+	Tx8+	Tx14+	Tx20+	Tx26+	Tx32+	Tx38+	Tx44+
31	RED-BLU	-	-	-	-	-	-	-	-
6	BLU-RED	-	-	-	-	-	-	-	-
32	RED-ORN	Rx2 -	Rx8 -	Rx14 -	Rx20 -	Rx26 -	Rx32 -	Rx38 -	Rx44 -
7	ORN-RED	Rx2+	Rx8+	Rx14+	Rx20+	Rx26+	Rx32+	Rx38+	Rx44+
33	RED-GRN	-48V2	-48V8	-48V14	-48V20	-48V26	-48V32	-48V38	-48V44
8	GRN-RED	GRD2	GRD8	GRD14	GRD20	GRD26	GRD32	GRD38	GRD44
34	RED-BRN	Tx3 -	Tx9 -	Tx15 -	Tx21 -	T27 -	Tx33 -	Tx39 -	Tx45 -
9	BRN-RED	Tx3+	Tx9+	Tx15+	Tx21	T27+	Tx33+	Tx39+	Tx45+
35	RED-SLT	-	-	-	-	-	-	-	-
10	SLT-RED	-	-	-	-	-	-	-	-
36	BLK-BLU	Rx3 -	Rx9 -	Rx15 -	Rx21 -	R27 -	Rx33 -	Rx39 -	Rx45 -
11	BLU-BLK	Rx3+	Rx9+	Rx15+	Rx21+	R27+	Rx33+	Rx39+	Rx45+
37	BLK-ORN	-48V3	-48V9	-48V15	-48V21	-4827	-48V33	-48V39	-48V45
12	ORN-BLK	GRD3	GRD9	GRD15	GRD21	GR27	GRD33	GRD39	GRD45
38	BLK-GRN	Tx4 -	Tx10 -	Tx16 -	Tx22 -	Tx28 -	Tx34 -	Tx40 -	Tx46 -
13	GRN-BLK	Tx4+	Tx10+	Tx16+	Tx22+	Tx28+	Tx34+	Tx40+	Tx46+
39	BLK-BRN	-	-	-	-	-	-	-	-
14	BRN-BLK	-	-	-	-	-	-	-	-
40	BLK-SLT	Rx4 -	Rx10 -	Rx16 -	Rx22 -	Rx28 -	Rx34 -	Rx40 -	Rx46 -
15	SLT-BLK	Rx4+	Rx10+	Rx16+	Rx22+	Rx28+	Rx34+	Rx40+	Rx46+
41	YEL-BLU	-48V4	-48V10	-48V16	-48V22	-48V28	-48V34	-48V40	-48V46
16	BLU-YEL	GRD4	GRD10	GRD16	GRD22	GRD28	GRD34	GRD40	GRD46
42	YEL-ORN	Tx5 -	Tx11 -	Tx17 -	Tx23 -	Tx29 -	Tx35 -	Tx41 -	Tx47 -
17	ORN-YEL	Tx5+	Tx11+	Tx17+	Tx23+	Tx29+	Tx35+	Tx41+	Tx47+
43	YEL-GRN	-	-	-	-	-	-	-	-
18	GRN-YEL	-	-	-	-	-	-	-	-
44	YEL-BRN	Rx5 -	Rx11 -	Rx17 -	Rx23 -	Rx29 -	Rx35 -	Rx41 -	Rx47 -
19	BRN-YEL	Rx5+	Rx11+	Rx17+	Rx23+	Rx29+	Rx35+	Rx41+	Rx47+
45	YEL-SLT	-48V5	-48V11	-48V17	-48V23	-48V29	-48V35	-48V41	-48V47
20	SLT-YEL	GRD5	GRD11	GRD17	GRD23	GRD29	GRD35	GRD41	GRD47
46	VIO-BLU	Tx6 -	Tx12 -	Tx18 -	Tx24 -	Tx30 -	Tx36 -	Tx42 -	Tx48 -
21	BLU-VIO	Tx6+	Tx12+	Tx18+	Tx24+	Tx30+	Tx36+	Tx42+	Tx48+
47	VIO-ORN	-	-	-	-	-	-	-	-
22	ORN-VIO	-	-	-	-	-	-	-	-
48	VIO-GRN	Rx6 -	Rx12 -	Rx18 -	Rx24 -	Rx30 -	Rx36 -	Rx42 -	Rx48 -
23	GRN-VIO	Rx6+	Rx12+	Rx18+	Rx24+	Rx30+	Rx36+	Rx42+	Rx48+
49	VIO-BRN	-48V6	-48V12	-48V18	-48V24	-48V30	-48V36	-48V42	-48V48
24	BRN-VIO	GRD6	GRD12	GRD18	GRD24	GRD30	GRD36	GRD42	GRD48
50	VIO-SLT	-	-	-	-	-	-	-	-
25	SLT-VIO	-	-	-	-	-	-	-	-

Table 3 – S/T Interface 50-pin Connector Pinouts

Tone Commander NT1-296 Rack / NT1U-223TC Installation Instructions

Power

Rack Power Supply

1. Verify that the power output cable (red and black wires) is plugged into the rack's POWER connector.
2. Plug the power cord into a local 120 VAC, 60 Hz, single phase power outlet.

Battery Backup Power Supply

Refer to the NT1-200 Battery Backup Installation Instructions (doc. #13-102688) for Backup Battery power supply installation.

ISDN Terminal Power

ISDN terminals connected to the NT1s installed in the rack are powered from the NT1-296 Rack power supply. Terminal power can be provided by either of the following methods:

PS-2 – Direct power feed on Terminal jack pin 7 (-) and pin 8 (+), 5 watts average per NT1 circuit (250 watts maximum per rack, excluding NT1s).

PS-1 – Phantom power feed over the transmission pairs, Terminal jack pins 3/6 (+) and pins 4/5 (-), 4 watts maximum per NT1 circuit.

Mixed power can be used if maximums are not exceeded. Power connections to each NT1 are individually short circuit protected.

NT1U-223TC Card Status Indicators

The operating state of the NT1U-223TC is displayed by the two indicator lamps.

POWER (Red): ON STEADY when power is applied to the NT1.

STATUS (Green): OFF – No U interface (line error). Check connection to telco network.

FAST FLASH (8/sec.) – Attempting to link U interface with the telco network. A fast flash persisting longer than 15 seconds indicates that the NT1 is in a maintenance mode that was requested by the central office

SLOW FLASH (2/sec.) – U linked, S/T link not established with terminal. Check connection to terminal.

ON STEADY – Normal operation. U linked, and at least one S/T terminal linked.

Service

Repair of the NT1-296 Rack and NT1U-223TC card must be done by Tone Commander. Prior to equipment removal, call Tone Commander Customer Technical Support for assistance in determining the source of the problem. This critical action can often prevent needless removal of equipment and subsequent customer inconvenience.

Tone Commander
Customer Technical Support Department
11609 49th Place West
Mukilteo, WA 98275-4255 USA

Phone: (425) 349-1000
(800) 524-0024

E-mail: tech@tonecommander.com
Web: www.tonecommander.com

Fax: (425) 349-1010

Tone Commander is committed to meeting the product needs of our customers. Please write or call us with any suggestions for improvement.

FCC Requirements

The Tone Commander Models NT1-296 Rack and NT1U-223TC comply with Part 68 of the FCC Rules. The label affixed to this equipment contains, among other information, the FCC Registration for this equipment. You must, upon request, provide this information to your telephone company.

The following jacks must be ordered from the telephone company in order to interconnect this product with the public communication network: RJ21X.

If your NT1-296 Rack or NT1U-223TC causes harm to the telephone network, the Telephone Company may discontinue your service temporarily. If possible, they will notify you in advance. But if advance notice is not practical you will be notified as soon as possible. You will be informed of your right to file a complaint with the FCC.

Your telephone company may make changes in its facilities, equipment, operations or procedures that could affect the proper functioning of your equipment. If they do, you will be notified in advance to give you an opportunity to maintain uninterrupted telephone service.

If you have trouble with the NT1-296 Rack and NT1U-223TC, contact us at the address listed on page 8 of this manual for information on obtaining service or repairs. The telephone company may ask that you disconnect the telephone from the network until the problem has been corrected or until you are sure that the equipment is not malfunctioning.

The Tone Commander NT1-296 Rack and NT1U-223TC have been tested and found to comply with the limits for a Class B digital device, pursuant to Part 15 of the FCC Rules. These limits are designed to provide reasonable protection against harmful interference when the equipment is operated in a residential environment. This equipment generates, uses, and can radiate radio frequency energy and, if not installed and used in accordance with the instruction manual, may cause harmful interference to radio communications. However, there is no guaranty that interference will not occur in a particular installation. If this equipment does cause harmful interference to radio or television reception, which can be determined by turning the equipment off and on, the user is encouraged to try to correct the interference by one of the following measures:

- Where it can be done safely, re-orient the receiving television or radio antenna.
- To the extent possible, increase the separation between the telephone equipment and the television, radio, or other equipment.
- If your telephone equipment runs on AC power, plug your product into an AC outlet that is not on the same circuit as the one used by your radio or television receiver.

Tone Commander NT1-296 Rack / NT1U-223TC Installation Instructions

Tone Commander Product Warranty

For a period of one year from date of dealer purchase, but not to exceed 16 months from date of manufacture, Tone Commander Systems, Inc. (Tone Commander) warrants its products to be free from defects in material and workmanship under conditions of normal use and service. Tone Commander shall, at its option, repair or replace any defective product which, in its opinion, has not been misused, damaged, or improperly installed.

Repair or replacement under this warranty will be performed at Tone Commander's factory. Authorization must be obtained from Tone Commander prior to returning a product for repair. Freight must be prepaid for all units returned to Tone Commander. Units repaired under warranty will be shipped UPS Ground (or equivalent), freight prepaid by Tone Commander.

Products that are older than the warranty period, but less than 7 years old, or still manufactured by Tone Commander may be repaired at the factory for a flat rate charge. Repaired out-of-warranty units are warranted for 90 days from the date of repair.

The repair or replacement of a product under this warranty represents the entire obligation of Tone Commander; Tone Commander shall not be liable for any special or consequential damages resulting from or caused by any defect, failure, incapacity or malfunction of any of its products.

The foregoing express warranty is in lieu of all other warranties, express or implied, including, but not limited to any implied warranty of merchantability, fitness, or adequacy for any purpose or use, quality, productiveness or capacity; Tone Commander, to the extent permitted by law, hereby disclaims all such other warranties.